

F-430

Variable Area Flow Meter



Features

- > Durable, highly polished, one piece meter body
- > Annealed for added strength and chemical resistance
- > Acceptable in direct sunlight
- > Full scale accuracy +/- 5%
- > 316SS float & guide-wire

Highlights

Flow range

4.0 - 100 GPM
15 - 375 LPM

Pressures up to

130 PSI
(8.9 bar)

Max. fluid temp.

130 °F
54 °C

Body

Acrylic

Adapters

1.5" & 2.0" F/NPT

Warranty

1 Year



Maximum Working Pressure (Excluding pump tubes)	130 psi (8.9 bar) @ 70 °F (21 °C)
Maximum Fluid Temperature	130°F (54 °C) @ 0 PSI
Full Scale Accuracy	+/- 5%
Calibration Fluid	Water, specific gravity 1.0
Scale Length	5" (127mm)
Environment	Acceptable for direct sunlight exposure
Maximum Pressure Drop	3 PSI
Approximate Shipping Weight	6 lb (2.7kg)

Dimensions

Dim	Inch	cm
A	14"	35.6
B	3"	7.6

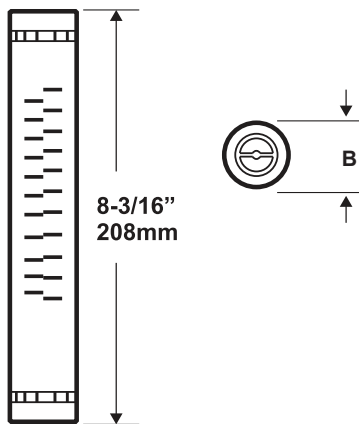

Maximum Temperature vs. Pressure

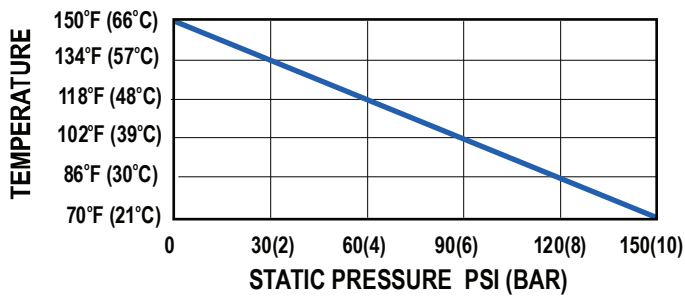

Wetted Components:

Meter Body	Cast acrylic rod
Adapters	PVC
Guide Rod Holder	Polysulfone
O-ring Seals	Viton®
Float	316ss
Guide Rod	316ss

Output Specifications

Model	Feed Rate		Max Pressure	Max Temperature	Float Material
	GPM	LPM	PSI (bar)	°F (°C)	
F-43040LNS	4–40	15–150	130 (8.9)	70 (21)	316SS
F-43060LNS	6–60	20–230	130 (8.9)	70 (21)	316SS
F-43080LNS	8–80	30–300	130 (8.9)	70 (21)	316SS
F-43100LNS	20–100	75–375	130 (8.9)	70 (21)	316SS

Model Number Matrix

F-430 Model Number

F	Flow Meter				
Series					
	43	F-430 Acrylic Body			
Scale					
	040	4 - 40 gpm (15 - 150 lpm) 316ss Float			
	060	6 - 60 gpm (20 - 230 lpm) 316ss Float			
	080	8 - 80 gpm (30 - 300 lpm) 316ss Float			
	100	20 - 100 gpm (75 - 375 lpm) 316ss Float			
Guide-Wire Material					
	LNS	3/16" Stainless steel rod with PVC adapters			
Adapter					
	(Blank)	2.0" Female/NPT			
	-24	1.5" Female/NPT			
F	-	43	040	LNS	Sample Model Number

*In-house NIST Calibration, OEM packaging and silicone oil free options are also available.